

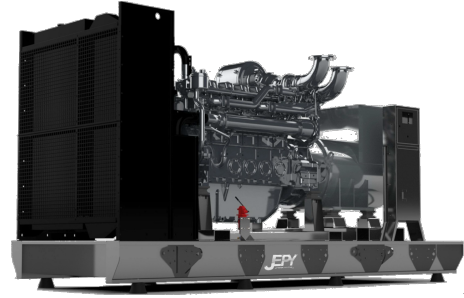

MP700EP



Output Rating				
Voltage	Frequency		Standby	Prime
400 V	50 Hz	KVA	770	700
		KW	616	560

Rating Definitions

Ratings are in accordance with ISO 8528, ISO 3046, BS 5514.

Prime Rating

Applicable for supplying continuous electrical power (no limitation to annual hours of operation), at variable load, in lieu of utility power network; 10% overload is permitted for 1 hour in every 12 hours.

Standby Rating

Applicable for supplying continuous electrical power, at variable load, in the event of a utility power failure; no overload is permitted on standby ratings.

Standard Reference Conditions

Standard reference conditions 25°C (77°F) Air Inlet Temp, 100m (328 ft) A.S.L. 30% relative humidity.

General Data	
Engine Make	Perkins
Engine Model	2806A-E18TTAG4
Alternator Make	Stamford
Alternator Model	HCI634G
Control Unit	DSE 7x20
Engine Speed: RPM	1500
Fuel Tank Capacity (l)	1300
Fuel Consumption Standby (l/hr)	160.6
Fuel Consumption Prime (l/hr)	144.2
Fuel Consumption 75% (l/hr)	108.1
Fuel Consumption 50% (l/hr)	75.8

Optional Features and Customization

Optional Features and Customization include:

- Weather and sound proof enclosure
- Stand-alone control panel
- Synchronizing panel
- Load sharing
- Residential silencer
- CE certification
- LV Circuit Breaker

Dimensions and Weights

	Length (mm)	Width (mm)	Height (mm)	Weight (Kg)	
				Dry	Wet
Open Set	3584	1690	2472	4926	TBA
Canopied Set	4908	2164	2515	6911	TBA

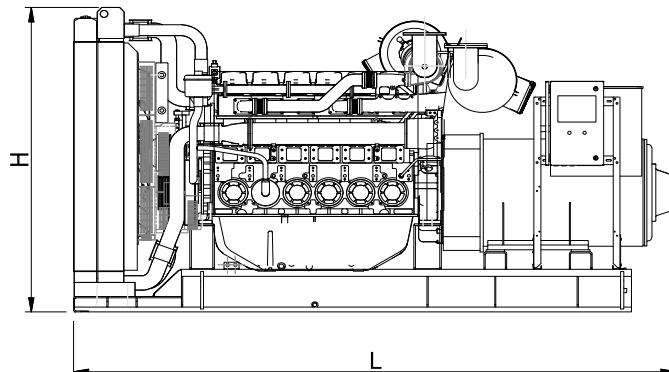
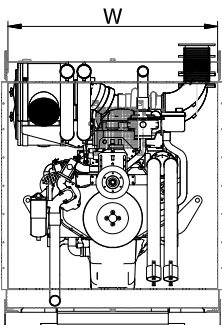

• Dimensions and weights are for guidance only. Certified drawings are available upon request. Specifications may change without notice.

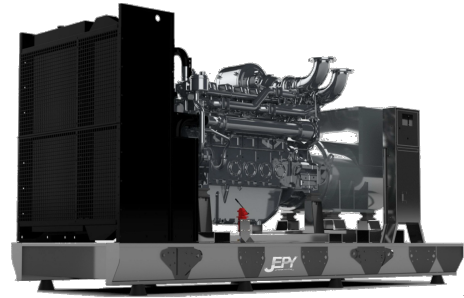

MP700EP

Engine Data

Engine Model	2806A-E18TTAG4	
No. of Cylinders	6	
Alignment	Vertical in-line	
Cycle	4 stroke	
Bore	mm (in)	145 (5.7)
Stroke	mm (in)	183 (7.2)
Induction	TC-AA	
Cooling Method	Water	
Governing Type	Electronic	
Governing Class	ISO 8528 G2	
Compression Ratio	14.0 : 1	
Displacement	L (cu.in)	18.1 (1104)
Moment of Inertia	kg m ²	3.95
Voltage	VDC	24
Ground	Negative	
Battery Charger Amps	50	
Engine Weight Dry	Kg (lb)	2361 (5205)
Engine Weight Wet	Kg (lb)	2477 (5461)

Engine Performance Data

Engine Speed	rpm	1500
Gross Engine Power Prime	kW (hp)	623 (835)
Gross Engine Power Standby	kW (hp)	685 (919)
BMEP Prime	kPa (psi)	2749 (398.7)
BMEP Standby	kPa (psi)	3023 (438.4)

Air System

Combustion Air Flow Prime	m ³ /min	52
Combustion Air Flow Standby	m ³ /min	57
Max. Combustion Air Intake Restri	kPa	3.7

Alternator Physical Data

No. of Bearings	1	
Insulation Class	H	
Winding Pitch	2/3	
Winding Code	N.A.	
Wires	12	
Ingress Protection Rating	IP23	
Excitation System	Self Excited	
AVR Model	MX321	
Radio Interference Suppression	EN61000-6	

Fuel System

Recommended Fuel	Class A2 Diesel	
Fuel Consumption Prime (110%)	l/hr	160.6
Fuel Consumption Prime (100%)	l/hr	144.2
Fuel Consumption Prime (75%)	l/hr	108.1
Fuel Consumption Prime (50%)	l/hr	75.8
Fuel Consumption Standby (110%)	l/hr	N.A.
Fuel Consumption Standby (100%)	l/hr	160.6
Fuel Consumption Standby (75%)	l/hr	119.0
Fuel Consumption Standby (50%)	l/hr	82.3
Fuel Consumption Continuous	l/hr	N.A.

(Based on diesel fuel with a specific gravity of 0.86 and conforming to BS2869 classA2, EN590)

Cooling System

Cooling System Capacity	(l)	110
Heat Radiation to Room*: Prime	kW	125
Heat Radiation to Room*: Standby	kW	136
Radiator Fan Load	kW	28
External Restriction to Airflow	Pa	125

Lubrication System

Oil Filter Type	Replaceable elt.	
Total Oil Capacity	(l)	68
Oil Pan Capacity:	(l)	55
Oil Type	SAE 15W40	
Oil Cooling Method	Water	

Exhaust System

Maximum Allowable Back Pressur	kPa	8.5
Exhaust Gas Flow: Prime	m ³ /min	120
Exhaust Gas Flow: Standby	m ³ /min	130
Exhaust Gas T°: Prime	°C	465
Exhaust Gas T°: Standby	°C	465

Alternator Operating Data

Overspeed	rpm	2250
Voltage Regulation: (Steady state)	%	±0.5
Total Harmonic content	%	5
Short Circuit Capacity	%	>200
Reactance (Xd)	%	283
Reactance (X'd)	%	23
Reactance (X''d)	%	16

• Dimensions and weights are for guidance only. Certified drawings are available upon request. Specifications may change without notice.