

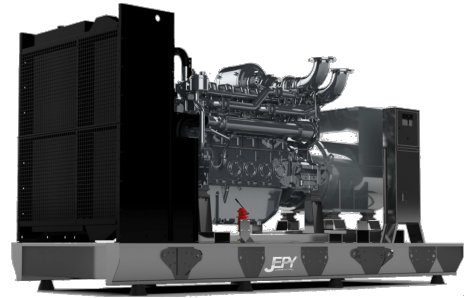

# MP450EP



Output Rating				
Voltage	Frequency		Standby	Prime
400 V	50 Hz	KVA	500	450
		KW	400	360

## Rating Definitions

Ratings are in accordance with ISO 8528, ISO 3046, BS 5514.

### Prime Rating

Applicable for supplying continuous electrical power (no limitation to annual hours of operation), at variable load, in lieu of utility power network; 10% overload is permitted for 1 hour in every 12 hours.

### Standby Rating

Applicable for supplying continuous electrical power, at variable load, in the event of a utility power failure; no overload is permitted on standby ratings.

### Standard Reference Conditions

Standard reference conditions 25°C (77°F) Air Inlet Temp, 100m (328 ft) A.S.L. 30% relative humidity.

General Data	
Engine Make	Perkins
Engine Model	2506A-E15TAG1
Alternator Make	Stamford
Alternator Model	S4L1DG
Control Unit	DSE 7x20
Engine Speed: RPM	1500
Fuel Tank Capacity (l)	630
Fuel Consumption Standby (l/hr)	104.0
Fuel Consumption Prime (l/hr)	95.0
Fuel Consumption 75% (l/hr)	72.0
Fuel Consumption 50% (l/hr)	50.0

## Optional Features and Customization

Optional Features and Customization include:

- Weather and sound proof enclosure
- Stand-alone control panel
- Synchronizing panel
- Load sharing
- Residential silencer
- CE certification
- LV Circuit Breaker

## Dimensions and Weights

	Length (mm)	Width (mm)	Height (mm)	Weight (Kg)	
				Dry	Wet
Open Set	3391	1410	1970	4120	TBA
Canopied Set	4900	1820	2463	5421	TBA

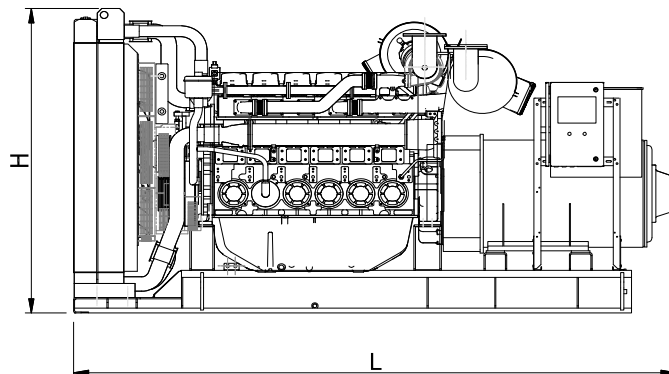
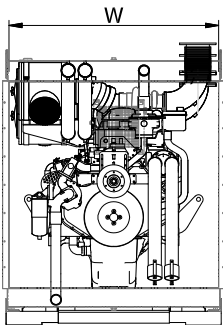

• Dimensions and weights are for guidance only. Certified drawings are available upon request. Specifications may change without notice.

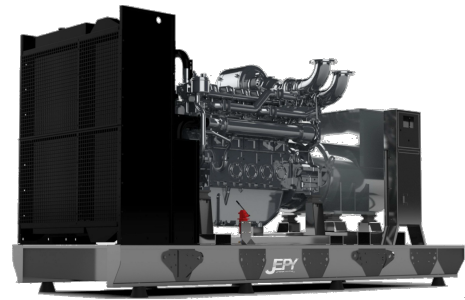

# MP450EP

## Engine Data

Engine Model	2506A-E15TAG1	
No. of Cylinders	6	
Alignment	Vertical in-line	
Cycle	4 stro	
Bore	mm (in)	137 (5.4)
Stroke	mm (in)	171 (6.7)
Induction	TC-AA	
Cooling Method	Water	
Governing Type	Electronic	
Governing Class	ISO 8528 G2	
Compression Ratio	16 : 1	
Displacement	L (cu.in)	15.2 (927)
Moment of Inertia	kg m <sup>2</sup>	4.29
Voltage	VDC	24
Ground	Negative	
Battery Charger Amps	70	
Engine Weight Dry	Kg (lb)	1633 (3600)
Engine Weight Wet	Kg (lb)	1714 (3779)

## Engine Performance Data

Engine Speed	rpm	1500
Gross Engine Power Prime	kW (hp)	412 (552)
Gross Engine Power Standby	kW (hp)	451 (605)
BMEP Prime	kPa (psi)	2235 (316.1)
BMEP Standby	kPa (psi)	2447 (346)

## Air System

Combustion Air Flow Prime	m <sup>3</sup> /min	26
Combustion Air Flow Standby	m <sup>3</sup> /min	31
Max. Combustion Air Intake Restri	kPa	6

## Alternator Physical Data

No. of Bearings	1	
Insulation Class	H	
Winding Pitch	2/3	
Winding Code	R1	
Wires	12	
Ingress Protection Rating	IP21	
Excitation System	Self Excited	
AVR Model	AS440	
Radio Interference Suppression	EN61000-6	

## Fuel System

Recommended Fuel	Class A2 Diesel	
Fuel Consumption Prime (110%)	l/hr	104.0
Fuel Consumption Prime (100%)	l/hr	95.0
Fuel Consumption Prime (75%)	l/hr	72.0
Fuel Consumption Prime (50%)	l/hr	50.0
Fuel Consumption Standby (110%)	l/hr	N.A.
Fuel Consumption Standby (100%)	l/hr	104.0
Fuel Consumption Standby (75%)	l/hr	78.5
Fuel Consumption Standby (50%)	l/hr	55.3
Fuel Consumption Continuous	l/hr	N.A.

*(Based on diesel fuel with a specific gravity of 0.86 and conforming to BS2869 classA2, EN590)*

## Cooling System

Cooling System Capacity	(l)	58
Heat Radiation to Room*: Prime	kW	53
Heat Radiation to Room*: Standby	kW	60
Radiator Fan Load	kW	14
External Restriction to Airflow	Pa	125

## Lubrication System

Oil Filter Type	Replaceable elt.	
Total Oil Capacity	(l)	62
Oil Pan Capacity:	(l)	53
Oil Type	SAE 15W40	
Oil Cooling Method	Water	

## Exhaust System

Maximum Allowable Back Pressur	kPa	6.8
Exhaust Gas Flow: Prime	m <sup>3</sup> /min	72
Exhaust Gas Flow: Standby	m <sup>3</sup> /min	81
Exhaust Gas T°: Prime	°C	550
Exhaust Gas T°: Standby	°C	550

## Alternator Operating Data

Overspeed	rpm	2250
Voltage Regulation: (Steady state)	%	±1.0
Total Harmonic content	%	5
Short Circuit Capacity	%	300
Reactance (Xd)	%	288
Reactance (X'd)	%	15
Reactance (X''d)	%	11

• Dimensions and weights are for guidance only. Certified drawings are available upon request. Specifications may change without notice.