

MP2000EP

Output Rating

Voltage	Frequency		Standby	Prime
400 V	50 Hz	KVA	2200	2000
		KW	1760	1600

Rating Definitions

Ratings are in accordance with ISO 8528, ISO 3046, BS 5514.

Prime Rating

Applicable for supplying continuous electrical power (no limitation to annual hours of operation), at variable load, in lieu of utility power network; 10% overload is permitted for 1 hour in every 12 hours.

Standby Rating

Applicable for supplying continuous electrical power, at variable load, in the event of a utility power failure; no overload is permitted on standby ratings.

Standard Reference Conditions

Standard reference conditions 25°C (77°F) Air Inlet Temp, 100m (328 ft) A.S.L. 30% relative humidity.

General Data

Engine Make	Perkins
Engine Model	4016-61TRG2
Alternator Make	Stamford
Alternator Model	PI 734F
Control Unit	DSE 7x20
Engine Speed: RPM	1500
Fuel Tank Capacity (l)	TBC
Fuel Consumption Standby (l/hr)	470.8
Fuel Consumption Prime (l/hr)	418.1
Fuel Consumption 75% (l/hr)	317.7
Fuel Consumption 50% (l/hr)	223.5

Optional Features and Customization

Optional Features and Customization include:

- Weather and sound proof enclosure
- Stand-alone control panel
- Synchronizing panel
- Load sharing
- Residential silencer
- CE certification
- LV Circuit Breaker

Dimensions and Weights

	Length (mm)	Width (mm)	Height (mm)	Weight (Kg)	
				Dry	Wet
Open Set	5900	2200	2625	12215	12525
Canopied Set	TBC	TBC	TBC	TBC	TBC

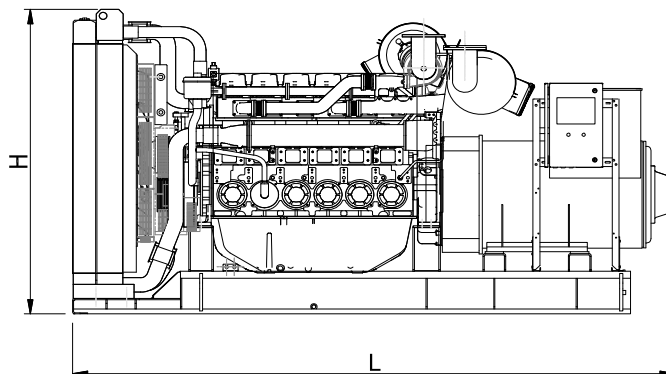
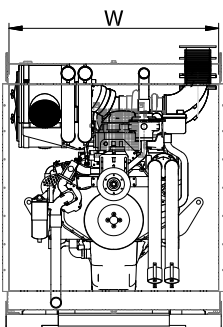

• Dimensions and weights are for guidance only. Certified drawings are available upon request. Specifications may change without notice.

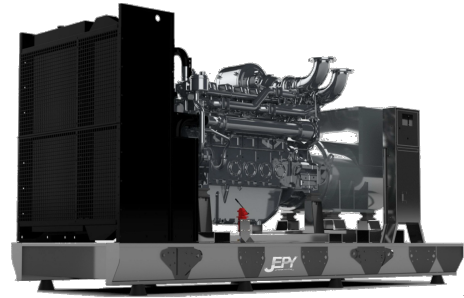

MP2000EP

Engine Data		
Engine Model		4016-61TRG2
No. of Cylinders		16
Alignment		60° Vee
Cycle		4 stroke
Bore	mm (in)	160 (6.3)
Stroke	mm (in)	190 (7.5)
Induction		TC AW
Cooling Method		WATER
Governing Type		ELECTRONIC
Governing Class		ISO 8528 G2
Compression Ratio		13 : 1
Displacement	L (cu.in)	61.123 (3730)
Moment of Inertia	kg m ²	20.72
Voltage	VDC	24
Ground		Negative
Battery Charger Amps		45
Engine Weight Dry	Kg (lb)	5570 (12280)
Engine Weight Wet	Kg (lb)	5600 (12350)

Engine Performance Data		
Engine Speed	rpm	1500
Gross Engine Power Prime	kW (hp)	1774 (2377)
Gross Engine Power Standby	kW (hp)	1985 (2659)
BMEP Prime	kPa (psi)	2322 (336.8)
BMEP Standby	kPa (psi)	2598 (376.8)

Air System		
Combustion Air Flow Prime	m ³ /min	158
Combustion Air Flow Standby	m ³ /min	175
Max. Combustion Air Intake Restri	kPa	3.7

Alternator Physical Data		
No. of Bearings		1
Insulation Class		H
Winding Pitch		2/3
Winding Code		N.A.
Wires		12
Ingress Protection Rating		IP23
Excitation System		N.A.
AVR Model		N.A.
Radio Interference Suppression		EN61000-6

• Dimensions and weights are for guidance only. Certified drawings are available upon request. Specifications may change without notice.

Fuel System		
Recommended Fuel		Class A2 Diesel
Fuel Consumption Prime (110%)	l/hr	470.8
Fuel Consumption Prime (100%)	l/hr	418.1
Fuel Consumption Prime (75%)	l/hr	317.7
Fuel Consumption Prime (50%)	l/hr	223.5
Fuel Consumption Standby (110%)	l/hr	N.A.
Fuel Consumption Standby (100%)	l/hr	470.8
Fuel Consumption Standby (75%)	l/hr	354.6
Fuel Consumption Standby (50%)	l/hr	246.4
Fuel Consumption Continuous	l/hr	N.A.

(Based on diesel fuel with a specific gravity of 0.86 and conforming to BS2869 classA2, EN590)

Cooling System		
Cooling System Capacity	(l)	270
Heat Radiation to Room*: Prime	kW	230
Heat Radiation to Room*: Standby	kW	250
Radiator Fan Load	kW	78
External Restriction to Airflow	Pa	250

Lubrication System		
Oil Filter Type		Replaceable elt.
Total Oil Capacity	(l)	237.2
Oil Pan Capacity:	(l)	213
Oil Type		SAE 15W40
Oil Cooling Method		Water-cooled

Exhaust System		
Maximum Allowable Back Pressur	kPa	4
Exhaust Gas Flow: Prime	m ³ /min	475
Exhaust Gas Flow: Standby	m ³ /min	475
Exhaust Gas T°: Prime	°C	457
Exhaust Gas T°: Standby	°C	489

Alternator Operating Data		
Overspeed	rpm	2250
Voltage Regulation: (Steady state)	%	±1
Total Harmonic content	%	<5
Short Circuit Capacity	%	>300
Reactance (Xd)	%	TBC
Reactance (X'd)	%	TBC
Reactance (X''d)	%	TBC