

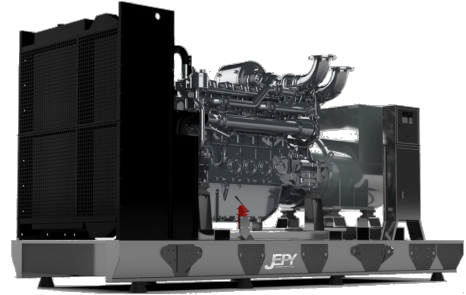

# MP3100EM



| Output Rating |           |     |         |       |
|---------------|-----------|-----|---------|-------|
| Voltage       | Frequency |     | Standby | Prime |
| 400 V         | 50 Hz     | KVA | 3355    | 3050  |
|               |           | KW  | 2684    | 2440  |

## Rating Definitions

Ratings are in accordance with ISO 8528, ISO 3046, BS 5514.

### Prime Rating

Applicable for supplying continuous electrical power (no limitation to annual hours of operation), at variable load, in lieu of utility power network; 10% overload is permitted for 1 hour in every 12 hours.

### Standby Rating

Applicable for supplying continuous electrical power, at variable load, in the event of a utility power failure; no overload is permitted on standby ratings.

### Standard Reference Conditions

Standard reference conditions 25°C (77°F) Air Inlet Temp, 100m (328 ft) A.S.L. 30% relative humidity.

| General Data                    |             |
|---------------------------------|-------------|
| Engine Make                     | MTU         |
| Engine Model                    | 20V4000G34F |
| Alternator Make                 | Leroy Somer |
| Alternator Model                | LSA53.2 M12 |
| Control Unit                    | DSE 7320    |
| Engine Speed: RPM               | 1500        |
| Fuel Tank Capacity (l)          | TBA         |
| Fuel Consumption Standby (l/hr) | 666.1       |
| Fuel Consumption Prime (l/hr)   | 599.1       |
| Fuel Consumption 75% (l/hr)     | 449.3       |
| Fuel Consumption 50% (l/hr)     | 312.0       |

## Optional Features and Customization

Optional Features and Customization include:

- Weather and sound proof enclosure
- Stand-alone control panel
- Synchronizing panel
- Load sharing
- Residential silencer
- CE certification
- LV Circuit Breaker

## Dimensions and Weights

|              | Length (mm) | Width (mm) | Height (mm) | Weight (Kg) |       |
|--------------|-------------|------------|-------------|-------------|-------|
|              |             |            |             | Dry         | Wet   |
| Open Set     | 6575        | 2050       | 2790        | 19492       | 19750 |
| Canopied Set | TBA         | TBA        | TBA         | TBA         | TBA   |

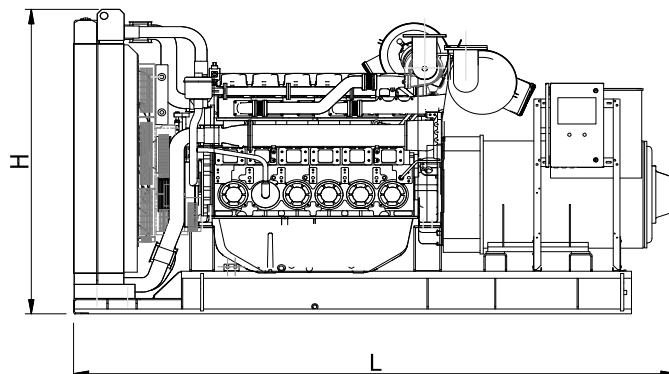
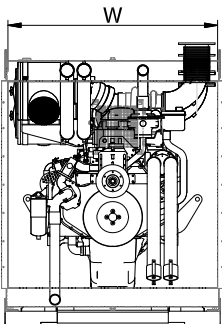

• Dimensions and weights are for guidance only. Certified drawings are available upon request. Specifications may change without notice.

# MP3100EM

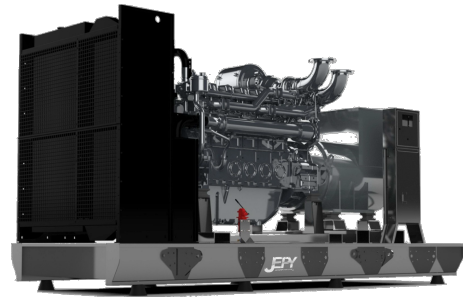

| Engine Data       |                   |              |
|-------------------|-------------------|--------------|
| Engine Model      |                   | 20V4000G34F  |
| No. of Cylinders  |                   | 20           |
| Alignment         |                   | 90° V        |
| Cycle             |                   | 4-cycle      |
| Bore              | mm (in)           | 170 (6.7)    |
| Stroke            | mm (in)           | 210 (8.3)    |
| Induction         |                   | TC-AC        |
| Cooling Method    |                   | Water        |
| Governing Type    |                   | Electronic   |
| Governing Class   |                   | ECU 9        |
| Compression Ratio |                   | 16.4         |
| Displacement      | L (cu.in)         | 4.77 (291)   |
| Moment of Inertia | kg m <sup>2</sup> | N.A.         |
| Voltage           | VDC               | 24           |
| Ground            |                   | Negative     |
| Capacity          |                   | N.A.         |
| Engine Weight Dry | Kg (lb)           | 9650 (21275) |
| Engine Weight Wet | Kg (lb)           | 9900 (21826) |

| Engine Performance Data    |           |             |
|----------------------------|-----------|-------------|
| Engine Speed               | rpm       | 1500        |
| Gross Engine Power Prime   | kW (hp)   | 2590 (3473) |
| Gross Engine Power Standby | kW (hp)   | 2850 (3822) |
| BMEP Prime                 | kPa (psi) | N.A.        |
| BMEP Standby               | kPa (psi) | N.A.        |

| Air System                        |                     |     |
|-----------------------------------|---------------------|-----|
| Combustion Air Flow Prime         | m <sup>3</sup> /min | 174 |
| Combustion Air Flow Standby       | m <sup>3</sup> /min | 198 |
| Max. Combustion Air Intake Restri | kPa                 | 5   |

| Alternator Physical Data  |  |                |
|---------------------------|--|----------------|
| No. of Bearings           |  | 1              |
| Insulation Class          |  | H              |
| Winding Pitch             |  | 2/3            |
| Winding Code              |  | N.A.           |
| Wires                     |  | N.A.           |
| Ingress Protection Rating |  | IP23           |
| Excitation System         |  | S-E, Brushless |
| AVR Model                 |  | Electronic     |

• Dimensions and weights are for guidance only. Certified drawings are available upon request. Specifications may change without notice.

| Fuel System                     |      |                 |
|---------------------------------|------|-----------------|
| Recommended Fuel                |      | Class A2 Diesel |
| Fuel Consumption Prime (110%)   | l/hr | 666.1           |
| Fuel Consumption Prime (100%)   | l/hr | 599.1           |
| Fuel Consumption Prime (75%)    | l/hr | 449.3           |
| Fuel Consumption Prime (50%)    | l/hr | 312.0           |
| Fuel Consumption Standby (110%) | l/hr | N.A.            |
| Fuel Consumption Standby (100%) | l/hr | 666.1           |
| Fuel Consumption Standby (75%)  | l/hr | 489.3           |
| Fuel Consumption Standby (50%)  | l/hr | 338.2           |
| Fuel Consumption Continuous     | l/hr | N.A.            |

(Based on diesel fuel with a specific gravity of 0.86 and conforming to BS2869 classA2, EN590)

| Cooling System                      |                     |      |
|-------------------------------------|---------------------|------|
| Cooling System Capacity             | (l)                 | N.A. |
| Heat rejection to coolant*: Prime   | kW                  | 950  |
| Heat rejection to coolant*: Standby | kW                  | 1050 |
| Fan power for mech. Rad. (40°C)     | kWm                 | 70   |
| Cooling air flow                    | m <sup>3</sup> /min | N.A. |

| Lubrication System |     |                  |
|--------------------|-----|------------------|
| Oil Filter Type    |     | Replaceable elt. |
| Total Oil Capacity | (l) | 390              |
| Oil Pan Capacity:  | (l) | N.A.             |
| Oil Type           |     | SAE 15W40        |
| Oil Cooling Method |     | Water            |

| Exhaust System                 |                     |     |
|--------------------------------|---------------------|-----|
| Maximum Allowable Back Pressur | kPa                 | 8.5 |
| Exhaust Gas Flow: Prime        | m <sup>3</sup> /min | 462 |
| Exhaust Gas Flow: Standby      | m <sup>3</sup> /min | 528 |
| Exhaust Gas T°: Prime          | °C                  | 565 |
| Exhaust Gas T°: Standby        | °C                  | 560 |

| Alternator Operating Data          |     |           |
|------------------------------------|-----|-----------|
| Overspeed                          | rpm | 2250      |
| Voltage Regulation: (Steady state) | %   | ±0.25     |
| Wave Form NEMA = TIF               |     | 50        |
| Wave Form IEC = THF                | %   | 20        |
| Total Harmonic content LL/LN       | %   | N.A.      |
| Radio Interference                 |     | EN61000-6 |
| Radiant Heat: 50 Hz                | kW  | N.A.      |