

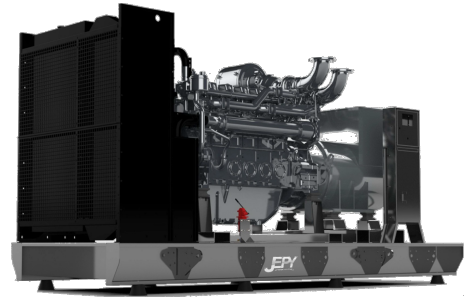

MP60EP



Output Rating				
Voltage	Frequency		Standby	Prime
400 V	50 Hz	KVA	63	60
		KW	50.4	48

Rating Definitions

Ratings are in accordance with ISO 8528, ISO 3046, BS 5514.

Prime Rating

Applicable for supplying continuous electrical power (no limitation to annual hours of operation), at variable load, in lieu of utility power network; 10% overload is permitted for 1 hour in every 12 hours.

Standby Rating

Applicable for supplying continuous electrical power, at variable load, in the event of a utility power failure; no overload is permitted on standby ratings.

Standard Reference Conditions

Standard reference conditions 25°C (77°F) Air Inlet Temp, 100m (328 ft) A.S.L. 30% relative humidity.

General Data	
Engine Make	Perkins
Engine Model	1103A-33TG2
Alternator Make	Stamford
Alternator Model	S1L2Y
Control Unit	DSE 7x20
Engine Speed: RPM	1500
Fuel Tank Capacity (l)	125
Fuel Consumption Standby (l/hr)	15.9
Fuel Consumption Prime (l/hr)	14.6
Fuel Consumption 75% (l/hr)	10.8
Fuel Consumption 50% (l/hr)	7.6

Optional Features and Customization

Optional Features and Customization include:

- Weather and sound proof enclosure
- Stand-alone control panel
- Synchronizing panel
- Load sharing
- Residential silencer
- CE certification
- LV Circuit Breaker

Dimensions and Weights

	Length (mm)	Width (mm)	Height (mm)	Weight (Kg)	
				Dry	Wet
Open Set	1700	700	1410	777	805
Canopied Set	2298	1104	1600	1137	1175

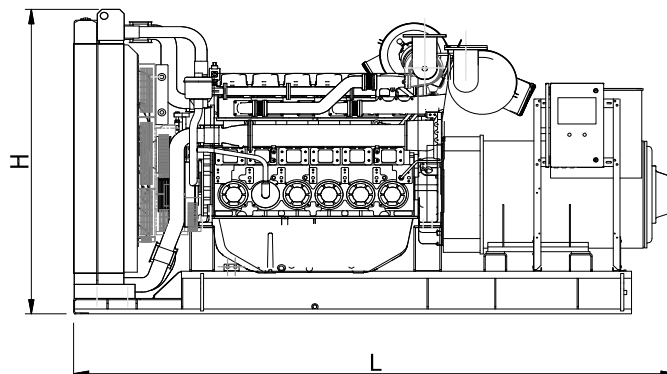
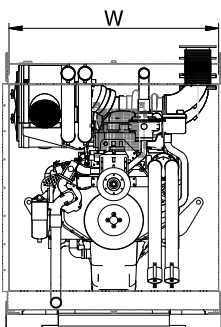

• Dimensions and weights are for guidance only. Certified drawings are available upon request. Specifications may change without notice.

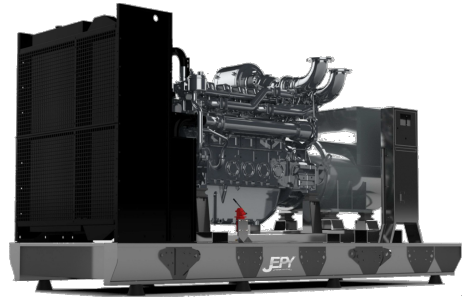

MP60EP

Engine Data		
Engine Model		1103A-33TG2
No. of Cylinders		3
Alignment		Vertical in-line
Cycle		4 stroke
Bore	mm (in)	105 (4.1)
Stroke	mm (in)	127 (5)
Induction		Turbocharged
Cooling Method		Water
Governing Type		Mechanical
Governing Class		ISO 8528 G2
Compression Ratio		17.25 : 1
Displacement	L (cu.in)	3.3 (201)
Moment of Inertia	kg m ²	N.A.
Voltage	VDC	12
Ground		65
Battery Charger Amps		Negative
Engine Weight Dry	Kg (lb)	420 (926)
Engine Weight Wet	Kg (lb)	N.A.

Engine Performance Data		
Engine Speed	rpm	1500
Gross Engine Power Prime	kW (hp)	55.0 (73.8)
Gross Engine Power Standby	kW (hp)	60.5 (81.1)
BMEP Prime	kPa (psi)	N.A.
BMEP Standby	kPa (psi)	N.A.

Air System		
Combustion Air Flow Prime	m ³ /min	3.8
Combustion Air Flow Standby	m ³ /min	3.9
Max. Combustion Air Intake Restri	kPa	8.0

Alternator Physical Data		
No. of Bearings		1
Insulation Class		H
Winding Pitch		2/3
Winding Code		N.A.
Wires		12
Ingress Protection Rating		IP23
Excitation System		Shunt
AVR Model		AS540
Radio Interference Suppression		EN61000-6

• Dimensions and weights are for guidance only. Certified drawings are available upon request. Specifications may change without notice.

Fuel System		
Recommended Fuel		Class A2 Diesel
Fuel Consumption Prime (110%)	l/hr	15.9
Fuel Consumption Prime (100%)	l/hr	14.6
Fuel Consumption Prime (75%)	l/hr	10.8
Fuel Consumption Prime (50%)	l/hr	7.6
Fuel Consumption Standby (110%)	l/hr	N.A.
Fuel Consumption Standby (100%)	l/hr	15.9
Fuel Consumption Standby (75%)	l/hr	11.7
Fuel Consumption Standby (50%)	l/hr	8.1
Fuel Consumption Continuous	l/hr	N.A.

(Based on diesel fuel with a specific gravity of 0.86 and conforming to BS2869 classA2, EN590)

Cooling System		
Cooling System Capacity	(l)	10.2
Heat Radiation to Room*: Prime	kW	15.2
Heat Radiation to Room*: Standby	kW	17.0
Radiator Fan Load	kW	1.0
External Restriction to Airflow	Pa	125

Lubrication System		
Oil Filter Type		Spin-on, Full flow
Total Oil Capacity	(l)	8.3
Oil Pan Capacity:	(l)	7.8
Oil Type		SAE 15W40
Oil Cooling Method		Water

Exhaust System		
Maximum Allowable Back Pressur	kPa	10.0
Exhaust Gas Flow: Prime	m ³ /min	10.1
Exhaust Gas Flow: Standby	m ³ /min	10.4
Exhaust Gas T°: Prime	°C	557
Exhaust Gas T°: Standby	°C	557

Alternator Operating Data		
Overspeed	rpm	2250
Voltage Regulation: (Steady state)	%	±1
Total Harmonic content	%	<5
Short Circuit Capacity	%	>300
Reactance (Xd)	%	224
Reactance (X'd)	%	17
Reactance (X''d)	%	12